



CG137-12 Oilfield Gas Generator Set

400 ekW (500 kVA)
448 bkW (600 bhp)
60 Hz 1800 rpm

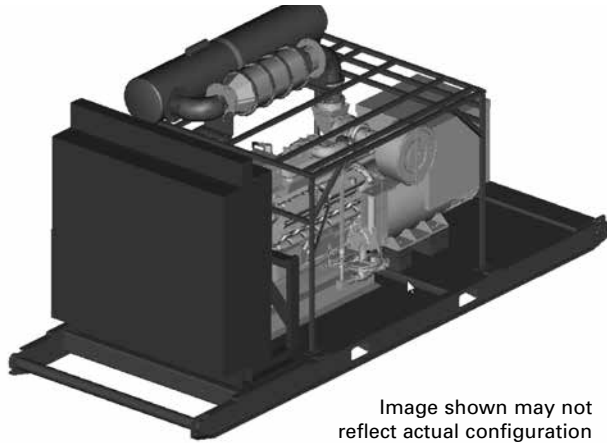

Image shown may not reflect actual configuration

CAT® GENERATOR SET SPECIFICATIONS

V12, 4-Stroke-Cycle

Emissions	0.5 g NSPS 2010
Bore	137 mm (5.39 in)
Stroke	164 mm (6.46 in)
Displacement	29 L (1770 in ³)
Compression Ratio	8.3:1
Aspiration	Turbocharged-Aftercooled
Engine Ignition and Control	Electronic ADEM A4
Engine Protection	Electronic ADEM A4
Generator Set Control	EMCP 4.3 (4.4 optional)
Generator	SR4B
Voltage	480
Full Rating Fuel Quality	Cat® MN 45
Minimum Fuel Quality	Cat MN 30

FEATURES

Product Design

- Fuel flexibility enables operation on a wide range of gas quality – from wellhead gas to pipeline quality natural gas
- Engine ratings developed to accept low-quality gas down to Cat MN 30
- Oversized SR4B generator optimized for block load acceptance and motor starting applications
- Package design and fuel flexibility allow minimum site preparation and low installation cost
- Heavy-duty base with tow bars and forklift pockets ideal for loading, transport, and unloading operations
- Open-skid configuration designed to integrate drop-over enclosure
- 4-point lifting structure

Superior Performance

- Superior gas engine transient capability
 - 50% G1 ISO 8528 load step
 - 30% G2 ISO 8528 load step
- Heavy-duty stacked core cooling system with low power draw and high ambient capability

Emissions Compliance

- 0.5 g NSPS site compliance with stationary application capability in non-attainment areas
- Includes factory-installed air-fuel ratio control and three-way catalyst

Durability

- Tough and durable, built specifically for conditions in the oilfield
- Rugged design optimized for harsh oilfield environments

Latest Electronics

- ADEM™ A4 control system provides integrated ignition, speed control, and protection
- Latest EMCP 4.3 controls for integrated engine-generator control, enhanced functionality, and simplified operator interface
- Optional EMCP 4.4 controls enable paralleling of up to eight units

Custom Packaging

For any petroleum application, trust Caterpillar to meet your project needs with custom factory generator sets and mechanical packages. Cat® engines, generators, controls, radiators, and transmissions can be custom-designed and matched in collaboration with our local dealers to create unique solutions. Custom packages are globally supported and are covered by a one-year warranty after startup.

Testing

- Every Cat generator set is full-load tested to ensure proper engine performance
- Generator sets are assembled, tested, and validated as a package to ensure performance, reliability and durability

Product Support Offered Through Global Cat Dealer Network

More than 2,200 dealer outlets

Cat factory-trained dealer technicians service every aspect of your petroleum engine

Caterpillar parts and labor warranty

Preventive maintenance agreements available for repair-before-failure options

S•O•SSM program matches your oil and coolant samples against Caterpillar set standards to determine:

- Internal engine component condition
- Presence of unwanted fluids
- Presence of combustion by-products
- Site-specific oil change interval

Web Site

For all your petroleum power requirements, visit www.catoilandgasinfo.com.



CONFIGURATION

Air Inlet System

Air cleaner - intermediate duty, dry
Air cleaner rain cap
Air cleaner service Indicator

Cooling System

High ambient radiator design for gas fuel applications
Stacked aftercooler and jacket water cores
Metal top and bottom tanks
Coolant drain
Fan and belt pulley guard
Coolant level sensor

Exhaust System

Exhaust manifolds – water cooled
Exhaust elbow and flex fitting – 127 mm (5 in)
Residential grade muffler
Three-way catalyst
Muffler mounting structure

Fuel System

Gas pressure regulator – requires 10.3-34.5 kPa
(1.5-5 psi) gas
Natural gas carburetor
Air-fuel ratio control
*1 micron gas filter

Generator

Rated for continuous duty – oversized 10%
Class H insulation
Permanent magnet
Random wound
240 VAC space heater
Coastal insulation protection
IP23 protection
Cat Digital Voltage Regulator

Control System

Electronic governing ADEM A4
Electronic diagnostics and fault logging
Momentary start/stop logic
High temp braided engine harness with 70-pin customer
connector and service tool connector

Lube System

Crankcase breather, top-mounted
Oil filter, spin-on, left-hand service
Dipstick, left-hand service
Oil pump – gear-driven
Oil cooler

Mounting System

Heavy-duty welded steel base designed for the oilfield
Base design optimized for loading and unloading

- Forklift pockets
- Tow bars – fore and aft
- Four-point lift from tow bars

Protection System

The following parameters include alarm and shutdown:

- Inlet manifold air temperature
- Inlet manifold air pressure
- Oil pressure
- Oil temperature
- Coolant temperature
- Engine overspeed
- Battery voltage

General

24V starting motor
24V, 60-amp charging alternator
*Jacket water heater

Warranty

- Entire package covered under a one-year Caterpillar warranty
- Warranty includes all components and content

*Indicates an optional attachment



CG137-12 OILFIELD GAS GENERATOR SET

400 ekW (500 kVA) 60 Hz

TECHNICAL DATA

CG137-12 Oilfield Gas Generator Set — 1800 rpm

	Units	DM9292-00
Generator Set Data		
Rated Power (includes fan power)	ekW	400
kVA Rating	kVA	500
Rated Power Factor	pf	0.8
Frequency	Hz	60
Engine Data		
Engine Power	bkW (bhp)	448 (600)
Engine Speed	rpm	1800
Min. Cat Methane Number without derate		45
BSFC @ 100% load	MJ/bkW-hr (Btu/bhp-hr)	10.47 (7405)
BSFC @ 75% load	MJ/bkW-hr (Btu/bhp-hr)	10.98 (7766)
BSFC @ 50% load	MJ/bkW-hr (Btu/bhp-hr)	12.08 (8544)
Air Flow Rate (@ 0°C, 101.3 kPa)	m³/min (ft³/min)	22.7 (800)
Inlet Manifold Pressure @ Rated Power	kPa (psi)	200 (29.0)
Aftercooler Water Temperature	°C (°F)	54 (129)
Jacket Water Temperature	°C (°F)	99 (210)
Exhaust Stack Temperature (engine out)	°C (°F)	543 (1009)
Exhaust Flow Rate (@ stack temperature, 101.3 kPa)	m³/min (ft³/min)	72.9 (2574)
Lube oil system capacity	L (gal)	170 (45)
Engine coolant capacity	L (gal)	55.5 (15)
Radiator coolant capacity (JW)	L (gal)	144 (38)
Radiator coolant capacity (AC)	L (gal)	144 (38)
Oil change interval	Hours	750
Emissions (NTE)		
NOx	g/bkW-hr (g/bhp-hr)	0.67 (0.50)
CO	g/bkW-hr (g/bhp-hr)	2.68 (2.00)
Generator Data		
Frame size		593
Voltage	Volts	480
Design KVA rating	kVA	680
Insulation class		UL 1446 Class H
Temperature rise (@ 40°C ambient temp)	°C	80
Overload		300%/10 sec
Coastal protection		Included
Excitation		PM
Number of poles		4
Winding		Random wound
Pitch		0.7333
Number of leads		6
Number of bearings		1
Ingress protection (IP) rating		23
Alignment		Close coupled
Space heater		Standard



FUEL USAGE GUIDE

Cat Methane Number	30	35	40	45	50	55	60	65	70	75	80
Set point timing	16	15.5	15.5	15	17	19	20.5	24.5	26.5	28	30
Deration factor	0.90	0.93	0.96	1.00	1.00	1.00	1.00	1.00	1.00	1.00	1.00

ALTITUDE AND AMBIENT DERATION FACTORS

	10°C	15°C	20°C	25°C	30°C	35°C	40°C	45°C
0 m	1.00	1.00	1.00	1.00	1.00	1.00	1.00	1.00
250 m	1.00	1.00	1.00	1.00	1.00	1.00	1.00	1.00
500 m	1.00	1.00	1.00	1.00	1.00	1.00	1.00	1.00
750 m	1.00	1.00	1.00	1.00	1.00	1.00	1.00	1.00
1000 m	1.00	1.00	1.00	1.00	1.00	1.00	1.00	1.00
1250 m	1.00	1.00	1.00	1.00	1.00	1.00	1.00	1.00
1500 m	1.00	1.00	1.00	1.00	1.00	1.00	1.00	1.00
1750 m	0.83	0.83	0.83	0.83	0.83	0.83	0.83	0.83

EMCP 4.3 FEATURES (4.4 OPTIONAL)

140 mm (5.5 in) Graphical Display

- Generator AC voltage
 - 3-phase (L-L & L-N)
 - ± 0.25% accuracy
- rpm and battery voltage
- Generator AC current (per phase and average)
- Generator frequency
- Power metering (kW, kVA, kVA_r, pf)
- Hour meters (kW-hour, kVA_r-hour)
- Engine oil pressure (psi, kPa, or bar)
- Engine oil temperature (°C or °F)
- Engine coolant temperature (°C or °F)
- Coolant level
- Multiple language support
- Engine start and crank attempt counter
- Real-time clock

Communication

- Accessory CAN data link
- RS-485 annunciator data link
- RS-485 SCADA (Modbus RTU)
- Ethernet SCADA (Modbus TCP)

Controls

- Auto/start/stop
- Engine cooldown timer
- Emergency stop
- Engine cycle crank
- Programmable cycle timer
- Paralleling up to eight units*

Generator Set Protection

- Over/under voltage
- Over/under frequency
- Generator phase sequence
- Over current (timed and inverse)
- Reverse kW, kVA

- Current balance
- Bus phase sequence*
- Low oil pressure
- High coolant temp
- Low coolant level
- Fail to start
- Overspeed

Outputs

- 16 (17*) programmable digital outputs
- 3 programmable (4-20 mA or ±10V)
- 2 programmable (PWM)

Inputs

- Emergency stop
- Remote start
- 12 programmable digital inputs
- Oil pressure and water temperature
- 3 (4*) programmable inputs (±10V, PWM, current, or resistive)
- Oil temperature, fuel level

Other Features

- 16 languages supported:
 - Arabic
 - Chinese
 - Danish
 - Dutch
 - English
 - Finnish
 - French
 - German
 - Greek
 - Italian
 - Japanese
 - Portuguese
 - Russian
 - Spanish
 - Swedish
 - Turkish
- Programmable security levels
- Reduced power mode
- Programmable kW relay
- Cat switchgear integration
- Status event log

*Optional EMCP 4.4 feature



CG137-12 OILFIELD GAS GENERATOR SET

400 ekW (500 kVA) 60 Hz

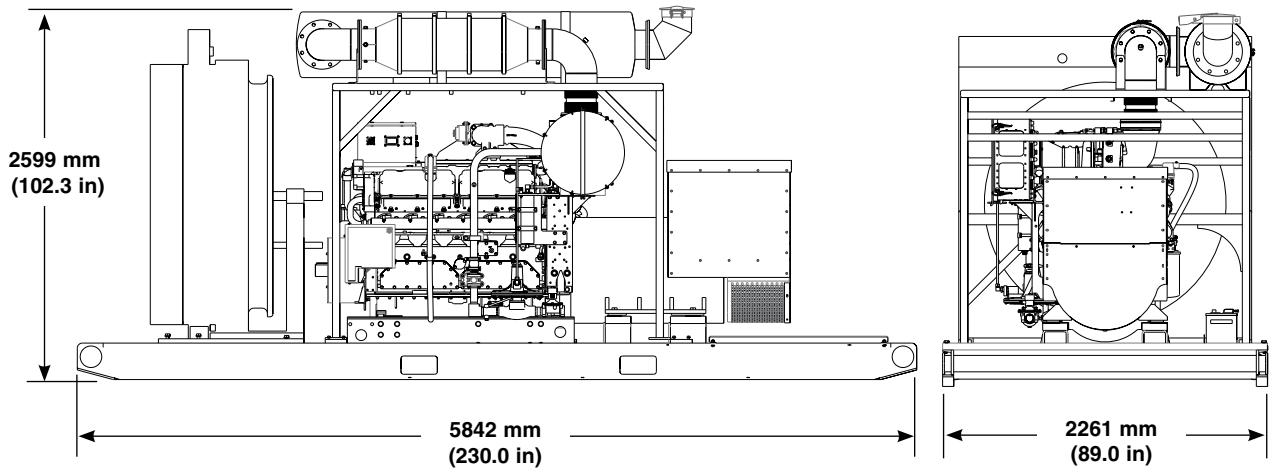

RIGHT SIDE VIEW

REAR VIEW

Generator Set Dimensions and Weight		
Length	5842 mm	230.0 in
Width	2261 mm	89.0 in
Height	2599 mm	102.3 in
Weight – dry*	8950 kg	19,731 lb

*Complete package weight

Note: Do not use for installation design. See installation drawing for details.

RATING DEFINITIONS AND CONDITIONS

Engine performance is obtained in accordance with SAE J1995, ISO3046/1, BS5514/1, and DIN6271/1 standards.

Transient response data is acquired from an engine/generator combination at normal operating temperature and in accordance with ISO3046/1 standard ambient conditions. Also in accordance with SAE J1995, BS5514/1, and DIN6271/1 standard reference conditions.

Conditions: Power for gas engines is based on fuel having an LHV of 33.74 kJ/L (905 Btu/cu ft) at 101 kPa (29.91 in Hg) and 15°C (59°F). Fuel rate is based on a cubic meter at 100 kPa (29.61 in Hg) and 15.6°C (60.1°F). Air flow is based on a cubic foot at 100 kPa (29.61 in Hg) and 25°C (77°F). Exhaust flow is based on a cubic foot at 100 kPa (29.61 in Hg) and stack temperature.

Materials and specifications are subject to change without notice. The International System of Units (SI) is used in this publication. CAT, CATERPILLAR, their respective logos, ADEM, S•O•S, "Caterpillar Yellow" and the "Power Edge" trade dress, as well as corporate and product identity used herein, are trademarks of Caterpillar and may not be used without permission.